



OR-PE120



POR SUS DIMENSIONES Y ESPESOR, ESTE MODELO NOS OFRECE UNA **MAYOR SEGURIDAD Y RESISTENCIA**. SE FABRICA EN SUS VERSIONES CIEGA, TROQUELADA CON VENTANAS DE 100MM X 50MM Y MICROPERFORADA CON TALADROS DE 3MM



zócalo

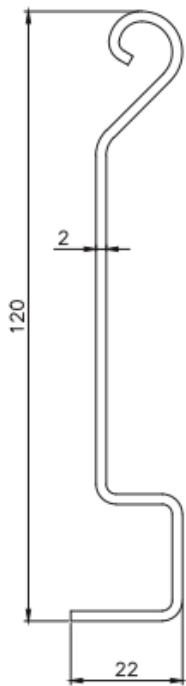

guia

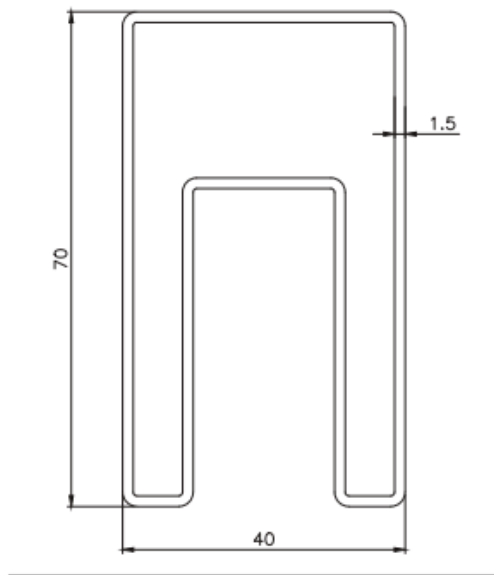

lama



CARACTERÍSTICAS TÉCNICAS

SUPERFICIE DE COBERTURA	120MM
ESPESOR NOMINAL	1 MM
ANCHO MÁX ACONSEJABLE	6,5M
ALTO MÁX ACONSEJABLE	5,5M
MODELOS	CIEGO, MICROPERFORADO Y TROQUELADO
ACABADOS	GALVANIZADO, LACADO AL HORNO Y ACERO INOXIDABLE

OR-PE120